

Zenith® Pumps

Planetary Gear Pumps

Precise, Pulseless,
Repeatable Performance
in Hot Melt Spin Pump
Applications



Zenith®
Pumps

Zenith original man-made fiber gear pump patent.

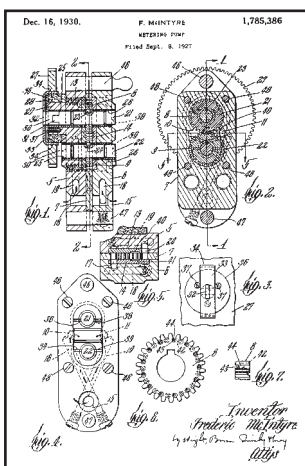

Since 1926, Zenith Pumps has provided the man-made fiber industry with precise, pulseless and repeatable gear metering pumps. From the earliest applications in viscose and hot-melt fiber spinning, through the more recent applications in high performance, specialty fibers, Zenith Pumps has met the challenges of the fiber industry with pumps of unmatched performance and quality.

As the largest spin pump supplier to the world's leading fiber producers, Zenith Pumps has remained in the forefront of gear pump developments

through ongoing programs of research into both pump design and precision part manufacturing. In addition, Zenith Pumps is committed to providing superior quality and customer service with two state-of-the-art, ISO certified production facilities fully integrated to ensure that our fiber producer customers have a reliable source of supply for their critical gear pump needs. Our customer support efforts are further enhanced by a worldwide network of direct offices, service facilities and sales representatives to respond to the demands of the fiber industry.

Planetary Pumps For Textile Denier Melt Fiber Spinning

The planetary pumps described in this catalog were developed by Zenith Pumps to maximize melt fiber production yields and run time. The pumps are available in configurations with 2, 3, 4, 6, or 8 metered outlet streams per pump and in displacements covering the throughput range of 0.1 to 8 liters/hour per stream. When properly installed and operated, the spin pumps provide the fiber producer the following important benefits.

- **Outstanding stream to stream and pump to pump metering uniformity** resulting from superior design, quality and wear resistance.
- **Reduced polymer shear and downstream thermal gradients** resulting

from optimized gear geometry and internal flow paths.

- **Superior pump pressure capability** resulting from high strength components including a full diameter coupling housing plate.
- **Superior pump toughness and durability** resulting from through hardened, particle metallurgy components.

In addition to these benefits, the single gear level planetary pump models offer greater stream to stream process temperature uniformity resulting in improved yarn consistency and processability as compared with multi gear level style pumps.

Specifications

Pump Model	Displacement Range (cm ³ /rev/port)	Outlet Ports	Gear Levels	Speed Range (rpm)	Inlet Press. Range		Outlet Press. Maximum*		Viscosity Maximum	
					bar	psi	bar	psi	Poise	Pa-s
HSC-6188	0.4 - 3.6	2	1	6 - 40	10-100	145-1450	500	7200	5000	500
HSD-6191	0.4 - 3.6	3	1	6 - 40	10-100	145-1450	500	7200	5000	500
HSE-6187	0.4 - 3.6	4	1	6 - 40	10-100	145-1450	500	7200	5000	500
HSG-6189	0.6 - 4.8	6	1	5 - 27	10-100	145-1450	450	6500	5000	500
HSH-6192	0.4 - 3.6	6	2	6 - 40	10-100	145-1450	500	7200	5000	500
HSI-6190	1.2 - 6.0	8	1	4 - 20	10-70	145-1000	400	6000	5000	500
HSJ-6182	0.4 - 3.6	8	2	6 - 40	10-100	145-1450	500	7200	5000	500

* Assumes inlet pressure of 100 bar, (70 bar for HSI-6190, 8X1)

Pump Selection

The following is a general guide for use with the tables in this catalog in selecting a spin pump for most textile denier, melt polymer applications. If the pump models described in this catalog are not suitable for your particular needs, Zenith Pumps has more than 1,000 additional spin pump designs as well as extensive custom engineering and manufacturing capability to provide an optimum pump for almost any fiber spinning application. Beyond the technical data included in this catalog, Zenith Pumps can provide pump performance curves for each pump model describing the volumetric efficiency, operating torque, and temperature rise for any customer specified polymer. Finally, before placing your order, please confirm your pump selection with either the Zenith factory or your Zenith Pumps sales representative.

1) Choose a pump model from the table on opposite page based on your requirements for: number of metered output streams, inlet and outlet operating pressures, and maximum polymer viscosity. Additionally, in the case of 6 or 8 stream models, select either the single gear level or the dual gear level model based on your available installation space and/or the anticipated range in throughput.

2) Divide your design pumping rate per outlet stream expressed in cm³/minute by each of the displacements available for the selected model (see catalog page for each pump model) to determine the pump speed for each displacement. For the best overall performance, select the pump displacement that results in a pump speed within the following optimum ranges.

- 10-27 rpm for 2, 3, 4, dual level 6, and dual level 8 stream models
- 8-18 rpm for single level 6 stream models
- 6-14 rpm for single level 8 stream models

Steps 3 through 6 are used to verify the mechanical torque adequacy of the pump selected in step 2. If the pump is found to be acceptable, the calculated operating torque from step 5 can be used to size the pump drive.

3) Apply the maximum anticipated pump speed in rpm (N), and the pump (K₁) factor (see catalog page for pump model) to the following equation and calculate the average shear rate (SR) in the pump in sec⁻¹.

$$SR = N * K_1$$

4) Using this shear rate and a viscosity versus shear rate curve for the spin polymer at the process temperature, determine the apparent viscosity for the polymer (μ) in Poise. Note: Poise = 10 * Pa-s.

5) Apply the number of metered streams (n), the pump displacement per stream (D), the required pump differential pressure in bar (ΔP = Discharge - Inlet, note: bar = 14.5 * psi), the maximum anticipated pump speed in rpm (N), the apparent viscosity (μ) in Poise, and the pump (K₂) factor (see catalog page for pump model) to the following equation and calculate the pump operating torque (T) in N-m. Note: in-lbs = 8.85 * N-m.

$$T = (n * D * \Delta P / 62) + (N * \mu / K_2)$$

6) Compare this calculated value with the mechanical torque limit for the pump model (see catalog page for pump model) to verify the adequacy of the selected pump.

Model HSC-6188 Pump, 2 Outlet Ports X 1 Level



Displacement per Port (cm ³ /rev)	0.4 - 3.6
Speed Range (rpm)	6 - 40
Viscosity Max. (Poise, Pa-s)	5000, 500
Inlet Pressure Range (bar, psi)	10-100, 145-1450
Outlet Pressure Max. (bar, psi)	500, 7200*
Diff. Pressure Max. (bar, psi)	400, 5800†
Mech. Torque Max. (N-m, in-lbs)	See Table Below
Drive Shaft Seal	Mechanical Face with Tang Slot
Temp. Operating Max. (°C)	340*‡
Temp. Cleaning Max. (°C)	510°
Standard Material	High Speed Tool Steels

* Assumes inlet pressure of 100 bar

† Assumes viscosity of 2500 Poise and speed of 40 rpm

‡ Limit due to bolting, higher temperature bolting available

Displacement per Port (cm ³ /rev)	Dimension "X"		Mech. Torque Maximum		Sizing Factors		Pump Weight		Pump Assembly Number
	mm	inch	N-m	in-lbs	K ₁	K ₂	Kgs	lbs	
0.4	72.4	2.85	68	600	171	1810	4.5	10	11-61880-6000-0
0.6	73.6	2.90	96	850	171	1760	4.7	10	11-61880-7000-0
1.2	77.4	3.05	170	1500	171	1620	4.9	11	11-61880-9000-0
1.8	81.1	3.19	226	2000	171	1500	5.2	11	11-61881-0000-0
2.4	84.9	3.34	260	2300	171	1400	5.4	12	11-61880-0000-0
3.0	88.5	3.49	294	2600	171	1310	5.6	12	11-61881-5000-0
3.6	92.4	3.64	305	2700	171	1230	5.9	13	11-61881-4000-0

Parts List

Item Number	Part Description	Quantity per Pump
1	Drive Shaft	1
2	Rear Plate	1
3	Key	2
4	Driven Gear	2
5	Gear Plate	1
6	Arbor	2
8	Front Plate	1
9	Driving Gear	1
10	Coupling Housing Plate	1
11	Universal Seal Coupling	1
12	Hub Seal Plate	1
13	Plate Screw	8
14	Hub Screw	4
15	Dowel	2

Bolt Torque Table, Grade 12.9

Cap Screws	Bolt Size	Torque*		
		N-m	In-lbs	kgs-cm
For Plates	M6	11	96	111
For Hub	M8	26	232	267
For Mounting	M12	91	803	925

* Screws lubricated with high temperature thread lubricant, anti-seize compound.

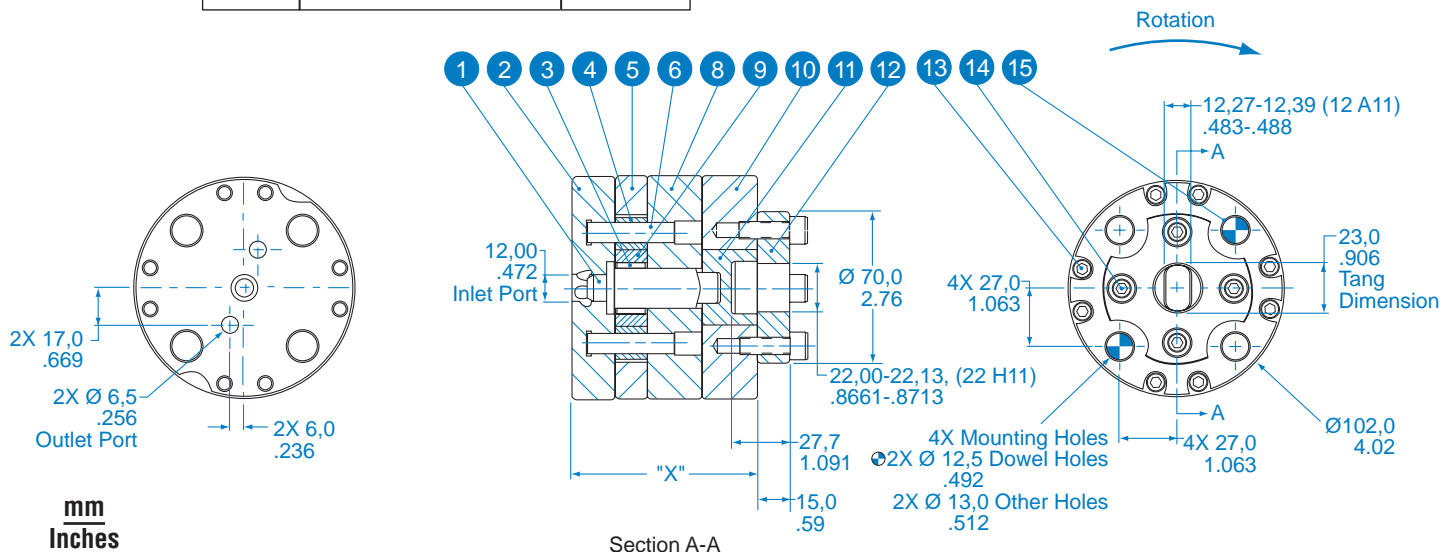

Model HSD-6191 Pump, 3 Outlet Ports X 1 Level



Displacement per Port (cm ³ /rev)	0.4 - 3.6
Speed Range (rpm)	6 - 40
Viscosity Max. (Poise, Pa-s)	5000, 500
Inlet Pressure Range (bar, psi)	10-100, 145-1450
Outlet Pressure Max. (bar, psi)	500, 7200*
Diff. Pressure Max. (bar, psi)	400, 5800†
Mech. Torque Max. (N-m, in-lbs)	See Table Below
Drive Shaft Seal	Mechanical Face with Tang Slot
Temp. Operating Max. (°C)	340*‡
Temp. Cleaning Max. (°C)	510°
Standard Material	High Speed Tool Steels

* Assumes inlet pressure of 100 bar

† Assumes viscosity of 2500 Poise and speed of 40 rpm

‡ Limit due to bolting, higher temperature bolting available

Displacement per Port (cm ³ /rev)	Dimension "X"		Mech. Torque Maximum		Sizing Factors		Pump Weight		Pump Assembly Number
	mm	inch	N-m	in-lbs	K ₁	K ₂	Kgs	lbs	
0.4	72.4	2.85	68	600	171	1720	4.5	10	11-61910-6000-0
0.6	73.6	2.90	96	850	171	1670	4.6	10	11-61910-7000-0
1.2	77.4	3.05	181	1600	171	1530	4.8	11	11-61910-9000-0
1.8	81.8	3.19	203	1800	171	1410	5.1	11	11-61911-0000-0
2.4	84.9	3.34	249	2200	171	1310	5.3	12	11-61910-0000-0
3.0	88.6	3.49	305	2700	171	1230	5.5	12	11-61911-5000-0
3.6	92.4	3.64	305	2700	171	1150	5.8	13	11-61911-4000-0

Parts List

Item Number	Part Description	Quantity per Pump
1	Drive Shaft	1
2	Rear Plate	1
3	Key	2
4	Driven Gear	3
5	Gear Plate	1
6	Arbor	3
8	Front Plate	1
9	Driving Gear	1
10	Coupling Housing Plate	1
11	Universal Seal Coupling	1
12	Hub Seal Plate	1
13	Plate Screw	6
14	Hub Screw	3
15	Dowel	2

Bolt Torque Table, Grade 12.9

Cap Screws	Bolt Size	Torque*		
		N-m	In-lbs	kgs-cm
For Plates	M6	11	96	111
For Hub	M8	26	232	267
For Mounting	M12	91	803	925

* Screws lubricated with high temperature thread lubricant, anti-seize compound.

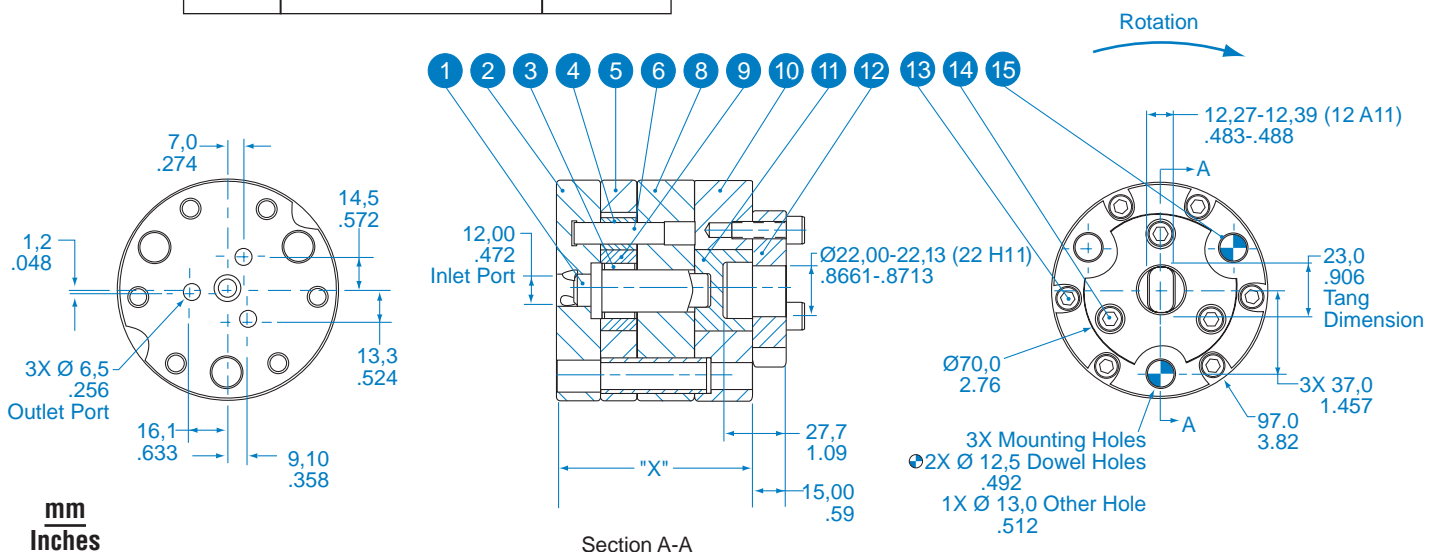

Model HSE-6187 Pump, 4 Outlet Ports X 1 Level



Displacement per Port (cm ³ /rev)	0.4 - 3.6
Speed Range (rpm)	6 - 40
Viscosity Max. (Poise, Pa-s)	5000, 500
Inlet Pressure Range (bar, psi)	10-100, 145-1450
Outlet Pressure Max. (bar, psi)	500, 7200*
Diff. Pressure Max. (bar, psi)	400, 5800†
Mech. Torque Max. (N-m, in-lbs)	See Table Below
Drive Shaft Seal	Mechanical Face with Tang Slot
Temp. Operating Max. (°C)	340**
Temp. Cleaning Max. (°C)	510°
Standard Material	High Speed Tool Steels

* Assumes inlet pressure of 100 bar

† Assumes viscosity of 2500 Poise and speed of 40 rpm

** Limit due to bolting, higher temperature bolting available

Displacement per Port (cm ³ /rev)	Dimension "X"		Inlet Port Diameter "d"		Mech. Torque Maximum		Sizing Factors		Pump Weight		Pump Assembly Number
	mm	inch	mm	inch	N-m	in-lbs	K ₁	K ₂	Kgs	lbs	
0.4	72.4	2.85	12	.472	68	600	171	1630	4.5	10	11-61870-6000-0
0.6	73.6	2.90	12	.472	96	850	171	1580	4.6	10	11-61870-7000-0
1.2	77.4	3.05	12	.472	181	1600	171	1450	4.8	11	11-61870-9000-0
1.8	81.1	3.19	12	.472	249	2200	171	1330	5.1	11	11-61871-0000-0
2.4	84.9	3.34	12	.472	305	2700	171	1234	5.3	12	11-61870-0000-0
3.0	88.6	3.49	12	.472	305	2700	171	1150	5.5	12	11-61871-5000-0
3.6	92.4	3.64	16	.630	305	2700	171	1080	5.8	13	11-61871-4000-0

Parts List

Item Number	Part Description	Quantity per Pump
1	Drive Shaft	1
2	Rear Plate	1
3	Key	2
4	Driven Gear	4
5	Gear Plate	1
6	Arbor	4
8	Front Plate	1
9	Driving Gear	1
10	Coupling Housing Plate	1
11	Universal Seal Coupling	1
12	Hub Seal Plate	1
13	Plate Screw	8
14	Hub Screw	4
15	Dowel	2

Bolt Torque Table, Grade 12.9

Cap Screws	Bolt Size	Torque*		
		N-m	In-lbs	kgs-cm
For Plates	M6	11	96	111
For Hub	M8	26	232	267
For Mounting	M12	91	803	925

* Screws lubricated with high temperature thread lubricant, anti-seize compound.

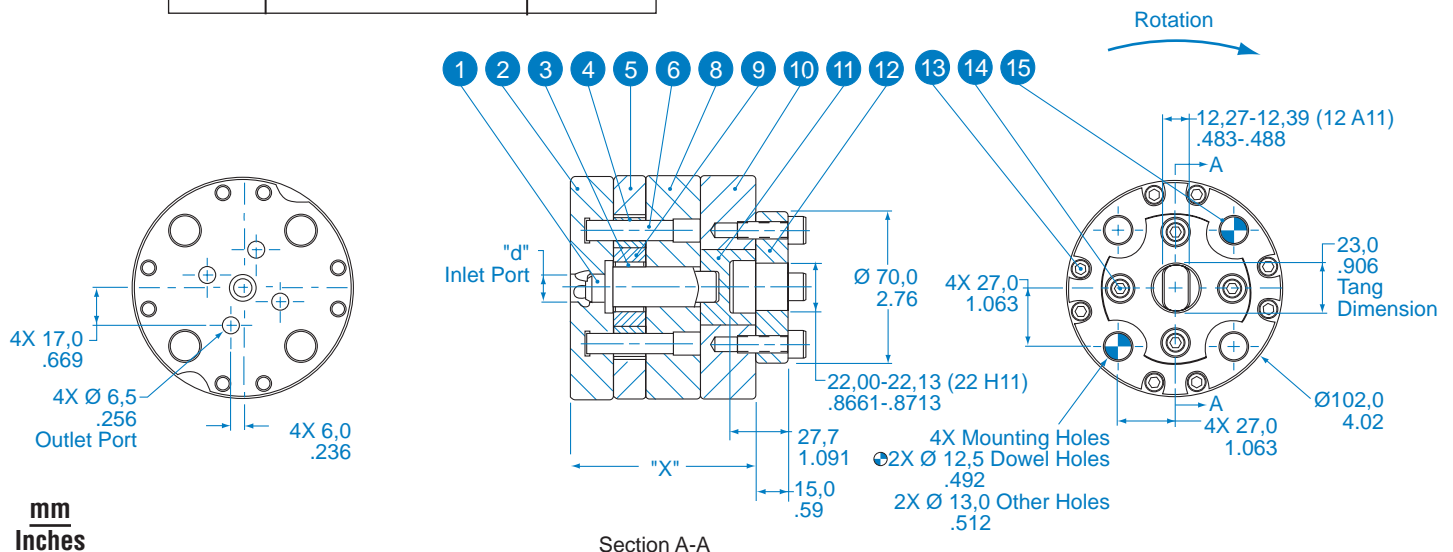

Model HSG-6189 Pump, 6 Outlet Ports X 1 Level



Displacement per Port (cm ³ /rev)	0.6 - 5.4
Speed Range (rpm)	5 - 27
Viscosity Max. (Poise, Pa-s)	5000, 500
Inlet Pressure Range (bar, psi)	10-100, 145-1450
Outlet Pressure Max. (bar, psi)	450, 6500*
Diff. Pressure Max. (bar, psi)	350, 5000†
Mech. Torque Max. (N-m, in-lbs)	See Table Below
Drive Shaft Seal	Mechanical Face with Tang Slot
Temp. Operating Max. (°C)	340*‡
Temp. Cleaning Max. (°C)	510°
Standard Material	High Speed Tool Steels

* Assumes inlet pressure of 100 bar

† Assumes viscosity of 2500 Poise and speed of 27 rpm

‡ Limit due to bolting, higher temperature bolting available

Displacement per Port (cm ³ /rev)	Dimension "X"		Mech. Torque Maximum		Sizing Factors		Pump Weight		Pump Assembly Number
	mm	inch	N-m	in-lbs	K ₁	K ₂	Kgs	lbs	
0.6	97.8	3.85	170	1500	224	573	6.7	15	11-61890-7000-0
1.2	100.4	3.95	350	3100	224	545	8.9	15	11-61890-9000-0
1.8	102.9	4.05	373	3300	224	520	7.0	15	11-61891-0000-0
2.4	105.5	4.15	373	3300	224	497	7.2	16	11-61890-0000-0
3.0	108.0	4.25	373	3300	224	476	7.4	16	11-61891-5000-0
3.6	110.6	4.35	373	3300	224	456	7.6	17	11-61891-4000-0
4.8	115.7	4.56	373	3300	224	422	7.9	17	11-61891-9000-0

Parts List

Item Number	Part Description	Quantity per Pump
1	Drive Shaft	1
2	Rear Plate	1
3	Key	2
4	Driven Gear	6
5	Gear Plate	1
6	Arbor	6
8	Front Plate	1
9	Driving Gear	1
10	Coupling Housing Plate	1
11	Universal Seal Coupling	1
12	Hub Seal Plate	1
13	Plate Screw	6
14	Hub Screw	6
15	Dowel	2

Bolt Torque Table, Grade 12.9

Cap Screws	Bolt Size	Torque*		
		N-m	In-lbs	kgs-cm
For Plates	M6	11	96	111
For Hub	M8	26	232	267
For Mounting	M12	91	803	925

* Screws lubricated with high temperature thread lubricant, anti-seize compound.

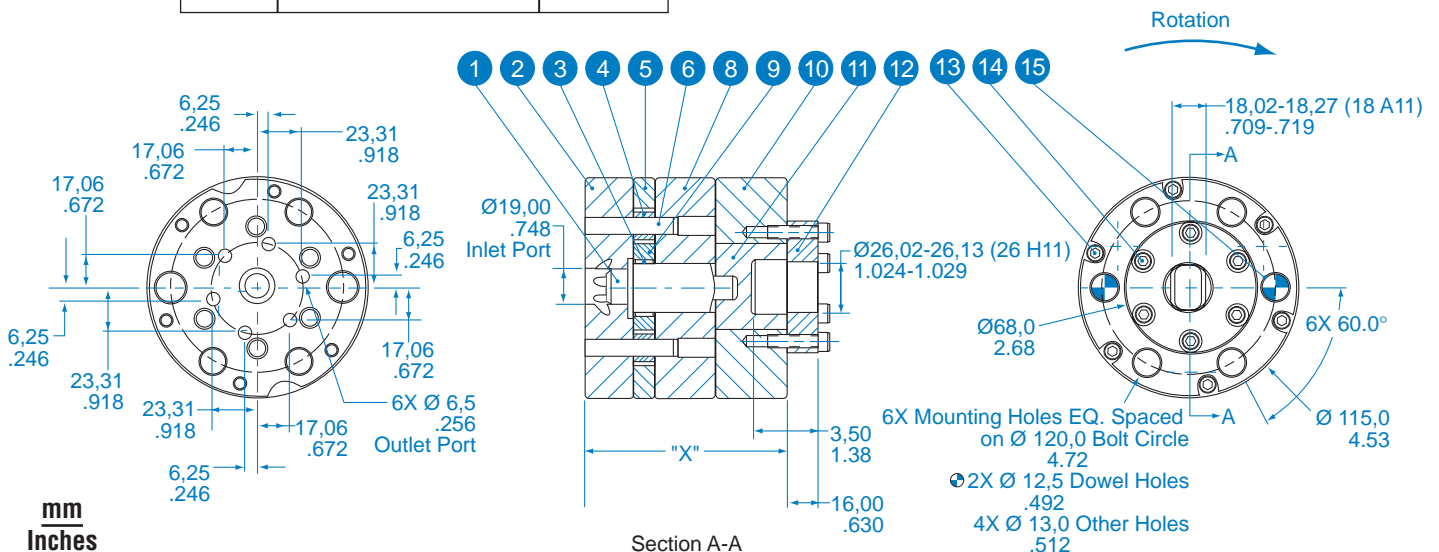

Model HSH-6192 Pump, 6 Outlet Ports X 2 Levels



Displacement per Port (cm ³ /rev)	0.4- 3.6
Speed Range (rpm)	6 - 40
Viscosity Max. (Poise, Pa-s)	5000, 500
Inlet Pressure Range (bar, psi)	10-100, 145-1450
Outlet Pressure Max. (bar, psi)	500, 7200*
Diff. Pressure Max. (bar, psi)	400, 5800†
Mech. Torque Max. (N-m, in-lbs)	See Table Below
Drive Shaft Seal	Mechanical Face with Tang Slot
Temp. Operating Max. (°C)	340*‡
Temp. Cleaning Max. (°C)	510‡
Standard Material	High Speed Tool Steels

* Assumes inlet pressure of 100 bar

† Assumes viscosity of 2500 Poise and speed of 40 rpm

‡ Limit due to bolting, higher temperature bolting available

Displacement per Port (cm ³ /rev)	Dimension "X"		Mech. Torque Maximum		Sizing Factors		Pump Weight		Pump Assembly Number
	mm	inch	N-m	in-lbs	K ₁	K ₂	Kgs	lbs	
0.4	90.7	3.57	113	1000	171	1080	5.7	12	11-61920-6000-0
0.6	93.2	3.67	170	1500	171	1040	5.8	13	11-61920-7000-0
1.2	100.7	3.97	283	2500	171	931	6.3	14	11-61920-9000-0
1.8	108.2	4.26	305	2700	171	846	6.8	15	11-61921-0000-0
2.4	115.7	4.56	305	2700	171	776	6.6	16	11-61920-0000-0
3.0	123.3	4.85	305	2700	171	716	7.7	17	11-61921-5000-0
3.6	130.8	5.15	305	2700	171	664	8.2	18	11-61921-4000-0

Parts List

Item Number	Part Description	Quantity per Pump
1	Drive Shaft	1
2	Rear Plate	1
3	Key	4
4	Driven Gear	6
5	Gear Plate	2
6	Arbor	3
7	Middle Plate	1
8	Front Plate	1
9	Driving Gear	2
10	Coupling Housing Plate	1
11	Universal Seal Coupling	1
12	Hub Seal Plate	1
13	Plate Screw	6
14	Hub Screw	3
15	Dowel	2

Bolt Torque Table, Grade 12.9

Cap Screws	Bolt Size	Torque*		
		N-m	In-lbs	kgs-cm
For Plates	M6	11	96	111
For Hub	M8	26	232	267
For Mounting	M12	91	803	925

* Screws lubricated with high temperature thread lubricant, anti-seize compound.

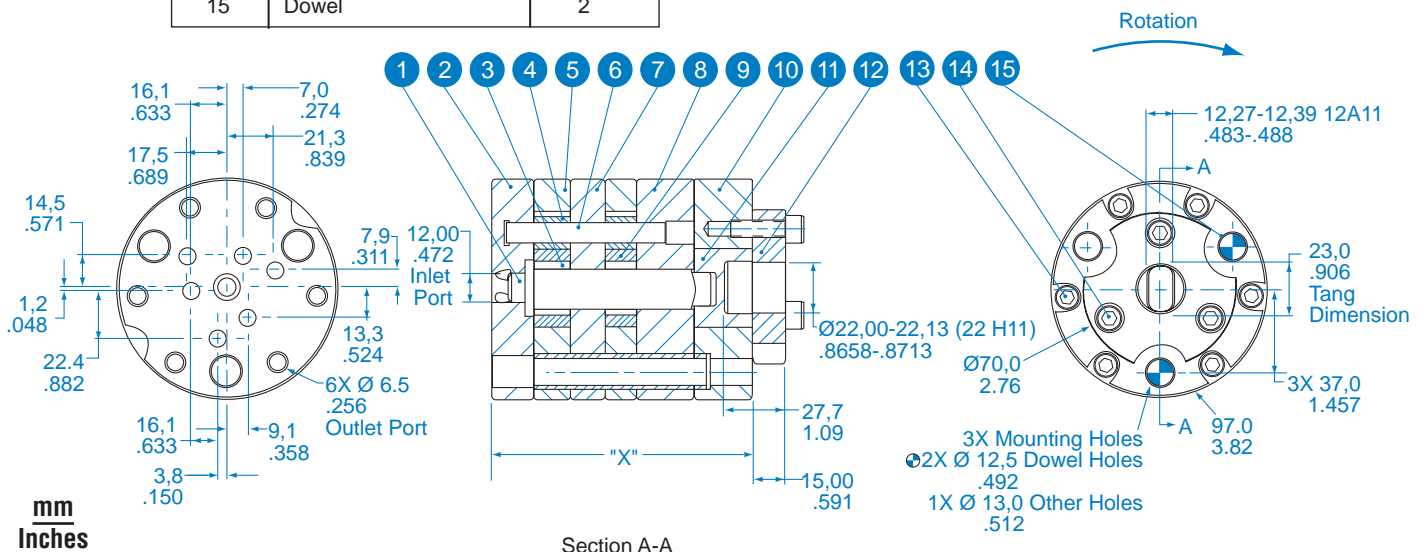

Section A-A

Model HSJ-6182 Pump, 8 Outlet Ports X 2 Levels



Displacement per Port (cm ³ /rev)	0.4- 3.6
Speed Range (rpm)	6 - 40
Viscosity Max. (Poise, Pa-s)	5000, 500
Inlet Pressure Range (bar, psi)	10-100, 145-1450
Outlet Pressure Max. (bar, psi)	500, 7200*
Diff. Pressure Max. (bar, psi)	400, 5800†
Mech. Torque Max. (N-m, in-lbs)	See Table Below
Drive Shaft Seal	Mechanical Face with Tang Slot
Temp. Operating Max. (°C)	340‡
Temp. Cleaning Max. (°C)	510‡
Standard Material	High Speed Tool Steels

* Assumes inlet pressure of 100 bar

† Assumes viscosity of 2500 Poise and speed of 40 rpm

‡ Limit due to bolting, higher temperature bolting available

Displacement per Port (cm ³ /rev)	Dimension "X"		Inlet Port Diameter "d"		Mech. Torque Maximum		Sizing Factors		Pump Weight		Pump Assembly Number
	mm	inch	mm	inch	N-m	in-lbs	K ₁	K ₂	Kgs	lbs	
0.4	90.7	3.57	12	.472	113	1000	171	1010	5.6	12	11-61820-6000-0
0.6	93.2	3.67	12	.472	181	1600	171	970	5.7	13	11-61820-7000-0
1.2	100.7	3.97	16	.630	305	2700	171	870	6.2	14	11-61820-9000-0
1.8	108.2	4.26	16	.630	305	2700	171	789	6.6	15	11-61821-0000-0
2.4	115.7	4.56	16	.630	305	2700	171	722	7.1	16	11-61820-0000-0
3.0	123.3	4.85	16	.630	305	2700	171	665	7.6	17	11-61821-5000-0
3.6	130.8	5.15	16	.630	305	2700	171	616	8.0	18	11-61821-4000-0

Parts List

Item Number	Part Description	Quantity per Pump
1	Drive Shaft	1
2	Rear Plate	1
3	Key	4
4	Driven Gear	8
5	Gear Plate	2
6	Arbor	4
7	Middle Plate	1
8	Front Plate	1
9	Driving Gear	2
10	Coupling Housing Plate	1
11	Universal Seal Coupling	1
12	Hub Seal Plate	1
13	Plate Screw	8
14	Hub Screw	4
15	Dowel	2

Bolt Torque Table, Grade 12.9

Cap Screws	Bolt Size	Torque*		
		N-m	In-lbs	kgs-cm
For Plates	M6	11	96	111
For Hub	M8	26	232	267
For Mounting	M12	91	803	925

* Screws lubricated with high temperature thread lubricant, anti-seize compound.

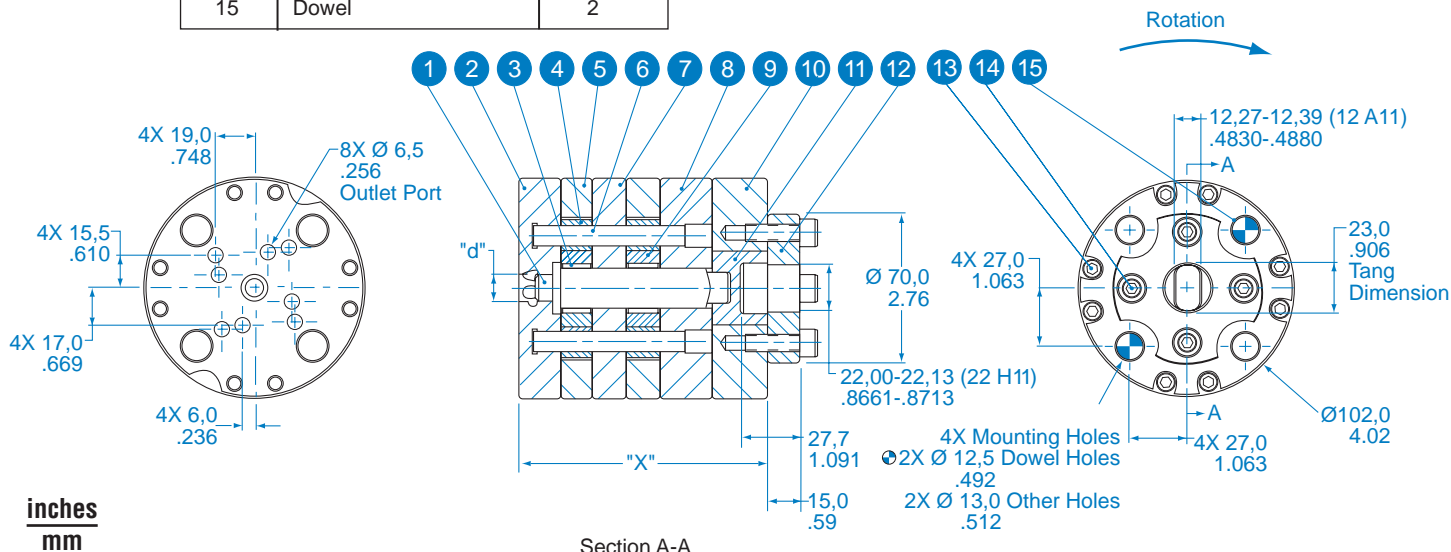

inches
mm

Drive Shaft Seal Options

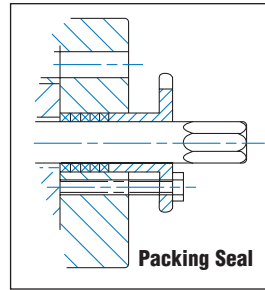
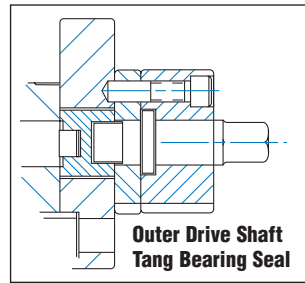

The standard pump models are supplied with universal coupling seals with a tang slot connection. Where improved performance of this type seal is required, an optional outer drive shaft with tang bearing is available. This design will prevent the possibility of drive shaft misalignment or axial loading from causing the coupling to improperly seat and leak. In addition to universal coupling seals, the pumps in this catalog are also available with high temperature packing seals.

Pump Mounting

To ensure the critical internal pump clearances are maintained and the highest possible metering performance is achieved, the surface to which the pumps are mounted should be flat within 0.0025 mm convex with a surface finish of 4 to 8 rms and the pump mounting bolts should be hot-torqued in three increments to the value speci-

fied in the Bolt Torque Tables. If replacement pump wear plates are needed due to damage or to accommodate a new pump design, Zenith Pumps can supply precision engineered and manufactured wear plates to ensure optimum gear pump performance.

Pump Contract Services

Zenith Pumps offers complete contract repair and service on all types of metering gear pumps used in the fiber industry. With two strategically located service facilities in North America servicing over 40,000 pumps annually, Zenith Pumps has unmatched expertise and resources for the maintenance of precision gear pumps. As a result of our experience and volume efficiencies, our customers save both

money and downtime while ensuring the fiber products they produce are of the highest quality.

In support of our maintenance services, Zenith Pumps provides replacement parts for a wide variety of Zenith and non-Zenith precision gear pumps. Please contact your local sales representative or the Zenith Pumps factory direct for further information on this service.

Pump Test Stands



To support fiber producers that elect to do their own pump repair and testing, Zenith Pumps provides custom engineered pump test stands for volumetric testing of spin pumps and spin finish pumps. Depending on the customer requirements, the test stands can be engineered with different numbers of test positions and different levels of automation. Please contact your local sales representative or the Zenith Pumps factory direct for further information on our pump test stands.



Sanford, NC



Aberdeen, NC



WARNING

FAILURE, IMPROPER SELECTION OR IMPROPER USE OF THE PRODUCTS AND/OR SYSTEMS DESCRIBED HEREIN OR RELATED ITEMS CAN CAUSE DEATH, PERSONAL INJURY AND PROPERTY DAMAGE.

This document and other information from Zenith Pumps, its subsidiaries and authorized distributors provide product and/or system options for further investigation by users having technical expertise. It is important that you analyze all aspects of your application and review the information concerning the product or system in the current product catalog. Due to the variety of operating conditions and applications for these products or systems, the user, through its own analysis and testing, is solely responsible for making the final selection of the products and systems and assuring that all performance, safety and warning requirements of the application are met.

The products described herein, including without limitation, product features, specifications, designs, availability and pricing, are subject to change by Zenith Pumps and its subsidiaries at any time without notice.

ISO 9001: 2000 Registered



Zenith® Pumps
 5910 Elwin Buchanan Drive
 Sanford, NC 27330-9551
 Phone: 919-774-7667 • Fax: 919-774-5952
 zenithpumps@colfaxcorp.com • www.zenithpumps.com