

Meydam Product range

Meydam
Vacuum system

Reference list

Norway

Land based installations, 3 pumps
M/S Reinefangst
M/S Que Vadis
M/S Solværgutt
M/S Grytafjord

Sverige

M/S Hollø
M/S Stella Nova

Scotland

Land based installations, 1 pump

Rep. South Africa

Oranjeviss St. Helena Bay factory
Oceania St. Helena Bay fishing factory

Australia

Tony's Tuna
S & Z Lukins
D. I. Fisheries

The vacuum system that always does the job.

Meydam delivers vacuum system with single or twin tank for continuous flow.

System capacity is 80m³, 100m³, 150m³ & 200m³ / hr.

We build our system around a liquid ring pump running at 1800rpm. This reduces the size of the electric motor by 20% compared to competing systems.

Meydam vacuum system is built for maximum security. All the modes can be controlled by the radio control as well as by the starter panel.

All parts in the vacuum pump is made of water resistant materials.

The system can be delivered with electric or hydraulic motor. We have chosen to use a standing tank as this gives the most efficient system.

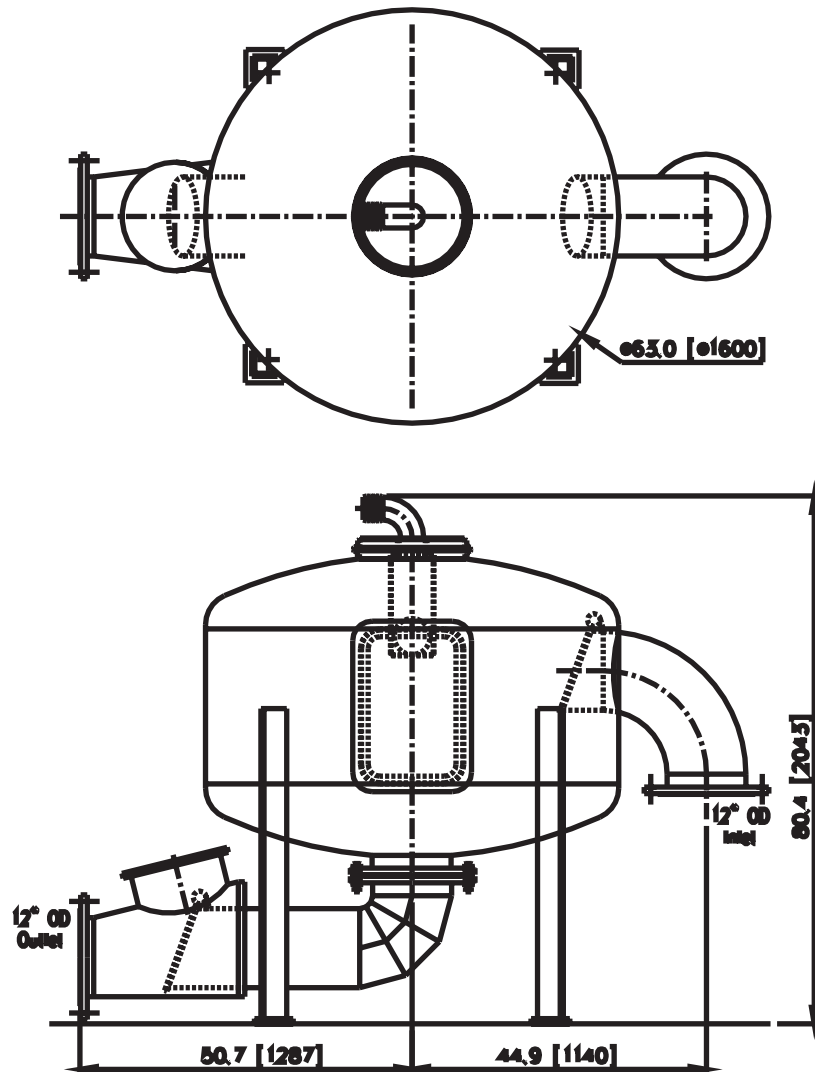

Meydam AS
Strandgt. 30 N-4379 Egersund
Norway
Phone +47 51 46 33 80
Telefax +47 51 46 33 90
E-mail: mail@meydam.com
www.meydam.com



Meydam
Vacuum systems

