

MONTACARGAS ELECTRICO SOOSUNG SBF-II

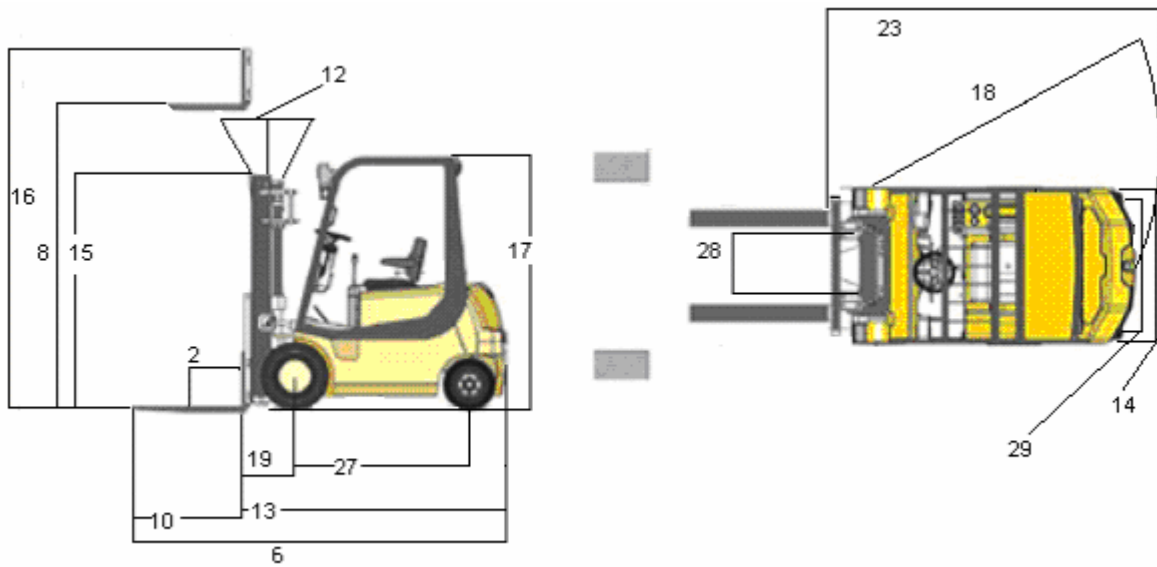



Comercializadora Industrial W&L Ltda.
 Av. Pdte. Eduardo Frei Montalva 6001 L. 82
 Centro empresarial El Cortijo
 Conchalí / Santiago / Chile
 Phone/Fax+56(2)9521000
 e-mail: ventas@w-l.cl

Nº	MODEL		UNIT	SBF-15II	SBF-18II	SBF-20II	SBF-25II
	Capacidad		kg	1500	1800	2000	2500
2	Centro de Carga		mm	500		500	
8	Altura de Levante		mm	3000		3300	
12	Inclinación		grado	6º adelante, 12º atrás			
	Velocidad de Levante		mm/seg	330/420	320/420	300/490	290/490
	Velocidad de Desplazamiento		km/h	11.2/13.1	11/13	14.2/16.9	13.8/16.5
18	Radio de Giro		mm	1877	1902	2097	2131
23	Gravedad con carga		%	13.7	12.3	13.5	11.9
6	Largo Total		mm	2910	2940	3314	3354
14	Ancho Total		mm	1068		1180	
17	Alto Total		mm	2105		2203	
15	Altura, Mástil abajo		mm	2105		2203	
16	Altura, Mástil extendido		mm	3395		4290 para estándar	
10	Largo de Horquillas		mm	900		1050	
19	Distancia de carga		mm	422		449.5	
	Peso incluida batería		kg	3000	3200	4200	4550
28	Llantas de	delantero	mm	903		955	
29	Ruedas	trasero	mm	915		960	
27	Distancia entre ejes		mm	1250		1530	
	Neumático	delantero		27 x 8 - 9		23 x 9 - 10	
		trasero		5.00 - 8		18 x 7 - 8	
	Control	manejo		FET		FET	
		Manejo carga		FET		FET	
	Motor hidráulico	tracción	kw	7.5		9.3	
		levante	kw	8		9	
	Batería	Voltaje	V	DC48		DC48	
		Capacidad	Ah	400		700	
	Cargador			3øx 220V/380V/400V			